

# ST Offline Tubing software -SigmaTUBE

## Features

- GUI Conforms to SolidWorks Environment
- Intuitive Arrangement of Tools and User Interface Provides a Hassle-Free Programming Environment
- Wizard Guides User along each Programming Step
- Automatic Cut-Out Recognition
- Automatic/Interactive Toolpath & NC Code Generation
- 3D Toolpath Simulation Displays: Tube, Cutting Head, and Machine
- Automatic Geometry Compensation for Normal to Surface Cuts
- Tabbing
- Automatic, Manual, and True Shape Nesting
- Cutting & Marking
- Torch Radius Compensation
- Support for Weld Preparation
- Variable Cutting Conditions Supported for Ramping on Knuckles
- Automatic/Interactive Sequencing of Cutting Path
- High-End Graphical Interface Provided to Edit the Tilt, Rotor, and Chuck Values when Tooling Intricate Shapes
- Collision Detection between Part and Torch

## Intelligent Feature Detection

SigmaTUBE automatically detects tube sections and features that must be cut on the machines. The software not only determines which loops and cuts need to be made but also recognizes lines, 3D arcs, and flat plane arcs. Rather than using a series of line segments, SigmaTUBE cuts a line or arc continuously resulting in faster and better cuts. Intelligent Feature Detection accelerates NC code generation.

## Toolpath Generation

SigmaTUBE guides the user through generating an optional multi-axis toolpath. Specifications such as coordinate system selections, toolpath parameters, rotation axes, and chord length parameters may be assigned. Automatic tool paths are generated based on tool path settings. For each contour, and lead-in/out, tool orientations can be modified. The cutting sequence can be calculated automatically or manually. Customized toolpaths can be generated on the contours manually. All nesting and toolpath data is stored with the SolidWorks assembly compatible with Product Data Management (PDM) systems.

## Nesting

SigmaTUBE offers powerful automatic, manual and true shape nesting to achieve optimal nesting results and minimize scrap. Efficient nesting is achieved by calculating best possible combinations based on actual geometry. Common-line cutting cuts shared edges at the same time reducing time and pierce points.

## NC Programming

Before generating NC code, SigmaTUBE provides a detailed, animated preview of the cutting process for each tube, including a display of rapid cuts. Although the efficiency of automatic generation can't be outdone, the user has the option to edit the toolpath and code. SigmaTUBE is compatible with all major laser and plasma cutting machines.

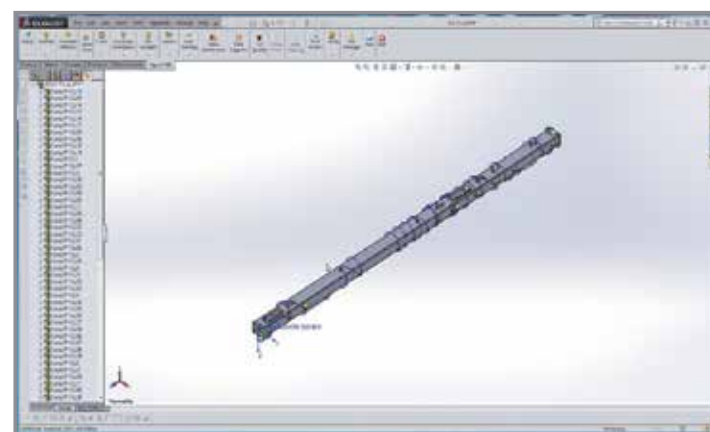
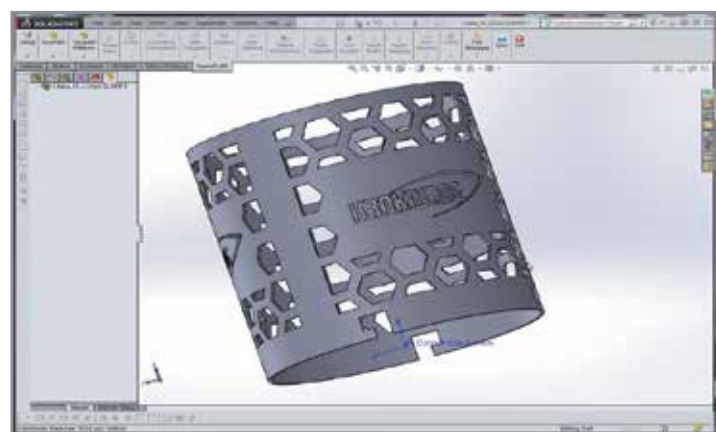

# TL 7525

High speed & heavy-duty  
Tube Laser Cutting System

Round up to 9.8" Diameter  
Square up to 6.9" x 6.9"  
Tube length up to 25"



# TL 6015

Unmatched performance and features  
based upon field-proven technologies

Round up to 6.5" Diameter  
Square up to 4.6" x 4.6"  
Tube length up to 19'8"



## Cutting Station



- Stress-analyzed heavy duty FC chuck
- FC 4-ways roller chuck structure
- Dead zone: 6.14"
- Fully enclosed cutting chamber
- Weld Seam Detector
- Slim-type Precitec cutting head (Fiber)
- Automatic open/close scrap window

## Part Removal Station



- Automatic scrap window drops the scrap while cutting
- When cutting process is complete, the scrap window is closed and the cut piece drops onto the upper deck to the part removal station
- Four (4) V-support to support the tube while cutting
- 10' length TL6015
- 12' length TL7525
- Scrap conveyor

## Bundle Loading System



- The bundle loading station can load tubes up to 11,000 lbs
- Max tube weight up to 640 lbs/ea
- Tube length for automated loading process: 20FT TL6015, 24FT TL7525
- Diameter sizes from .79" up to 9.84"
- Auto angle adjustment system for tubes
- Single stepper pushes up each tube to the pickup position
- Sheet measurement & Alignment device

## High Speed Rotary Chuck System



X-axis speed of the rotary chuck system driven by Siemens servo motors is more than 4700 IPM with 1G acceleration and its A-axis speed is 120 RPM; which enables high speed tube-cutting process.



### 15" Flat ScreenTouch-Panel

Siemens SINUMERIK 840D controller with 15" touchscreen monitor enables the system to run at high speed cycles, making the operator feel comfortable operating the system.

- Fully automated process system
  - Auto bundle loading & feeding
  - Auto rotary chuck clamping
  - Auto start for laser-cutting
  - Part removal station
- High speed processing
  - 4,724 IPM for X-axis
  - 120 RPM for A-axis
- High productivity and precision guaranteed by high-ends components
  - Siemens SINUMERIK 840D controller & drive
  - Field proven S5 (CO<sub>2</sub>) cutting head
  - Precitec cutting head (Fiber)
  - High precision rollers guide & rotary chuck
- Reliable 2.5KW laser sources with minimum maintenance cost

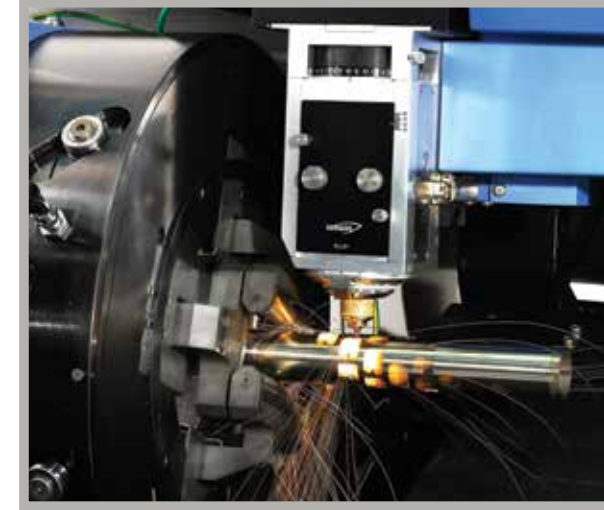

### High productivity laser machine

HK takes the next step forward in fully automated tube cutting systems with the introduction of the TL6015 and TL7525.

All our experience in tube cutting technology has joined with our expertise in the design and engineering of material handling systems to offer users a very affordable yet superior and highly flexible system for virtual non-stop production of tubes and shapes.

Coupled with our exclusive HK tubing software and fully controlled single CNC workstation, the TL Series will provide unmatched productivity to your operation.

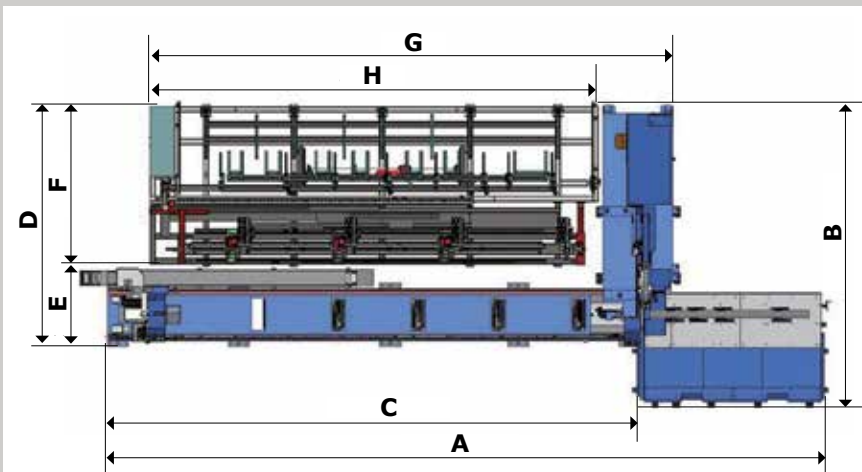

	TL6015	TL7525
<b>A</b>	529"	590"
<b>B</b>	215"	209"
<b>C</b>	346"	394"
<b>D</b>	153"	167"
<b>E</b>	51"	55"
<b>F</b>	102"	112"
<b>G</b>	322"	386"
<b>H</b>	277"	331"

### TL 7525 SPECIFICATIONS

Items	Specifications	
Laser	Laser Type	CO <sub>2</sub> , FIBER
	Output Power	2500 W (CO <sub>2</sub> ), 2000 W (FIBER)
Loading	Automatic	8' 2" ~ 24' 7"
	Max Unloading	11' 6" ( Option 23.0')
	Min Tube Length	6.14"
Size	Round	Φ 0.75" ~ Φ 9.84"
	Square	0.75" ~ 6.89"
Max Unit Weight	600 lbs	
Max Weight/ft	25 lbs/ft	
Max Bundle Weight	11,000 lbs	
Max Positioning Speed	X Axis	3,937 IPM
	Y Axis	2,362 IPM
	Z Axis	590 IPM
	A Axis	120 IPM
Accuracy	Positioning	± 0.0078"
	Repeatability	± 0.002"

### TL 6015 SPECIFICATIONS

Category	Items	Specifications
Laser	Laser Type	CO <sub>2</sub> , FIBER
	Output Power	2500 W (CO <sub>2</sub> ), 2000 W (FIBER)
Length of Tube Material	For Manual Loading (max)	25' 3"
	For Automatic Loading (max)	21' 4"
	Tube Cutting Length (max)	19' 8"
	Min. Tube Length	6.14"
Diameter of Tube Material	Round	6.5"
	Square	4.6" x 4.6"
	Rectangle	Diagonal 6.5"
Wall Thickness	Mild Steel	0.25"
	Stainless Steel	0.20"
	Aluminum	0.16"
Accuracy	Positioning Accuracy	+/-0.0078"
	Repeatability	+/-0.002"
Speed	X Axis	3937 IPM
	Y Axis	2382 IPM
	Z Axis	590 IPM
	A Axis	120 RPM
Max. Workpiece Weight/ft		13.5 lbs/ft

\* Max Cut thickness is typical and only for reference, not guaranteed, and varies depending upon the material quality and the cutting parameters and circumstances.  
 \* Specifications are subject to change without notice.



# TL Series

## Tube Laser Cutting System



Distributor