

## HIGH-PERFORMANCE DELIVERS HIGHER PROFITS

The HORNET HD dual side drive is the most cost-effective, best valued CNC plasma cutting machine on the market. Its compact dual-side drive design offers a rigid all steel precision machined frame with an independent cutting table and can be used with both air downdraft and water tables.

### FEATURING

#### DURABLE STEEL CONSTRUCTION



STRONG, RIGID, LONG-LASTING HEAVY-DUTY STEEL CONSTRUCTION MEANS YEARS OF UNMATCHED PRODUCTIVITY.

- Gantry and machine are fabricated from heavy-duty industrial grade steel.
- Components stress relieved prior to machining
- Heavy-duty steel-constructed table

#### VERSATILITY



FLEXIBLE, ADAPTABLE, MULTI-PURPOSE DESIGN ALLOWS MACHINE TO BE EASILY ADAPTED TO A MULTITUDE OF TASKS.

- Master tool carriage capable of handling 2 tools; plasma, oxy-fuel or air scribe
- Independent table design allows machine to be configured with either an air downdraft or water table

#### EXCEPTIONAL MOTION CONTROL



INCREASED PART PRODUCTION, LESS WASTE AND MORE UPTIME FROM HIGH-PERFORMANCE COMPONENTS.

- Linear rails on all axes
- Low backlash gear boxes
- Precision helical gear rack
- Powerful, precise, AC servo motors

## MACHINE SPECIFICATIONS

Positioning accuracy: +/- .005" (.127mm)\*  
 Repeatability: +/- .001" (.025mm)\*  
 \*Measured in a 60" x 60" area (1.5m x 1.5m)

	5ft (1.5m)	6.6ft (2.0m)	8.2ft (2.5m)	10ft (3.0m)
Nominal Cutting Width (A)	60" (1.52m)	79.20" (2.01m)	98.40" (2.50m)	120" (3.05m)
Nominal Cutting Length (B)	144" (3.66m)	240" (6.10m)	288" (7.32m)	
Width Between Side Frames (C)	71.25" (1.81m)	90" (2.29m)	109.75" (2.79m)	131.25" (3.33m)
Overall Machine Width (D)	103" (2.62m)	122" (3.10m)	142" (3.61m)	163" (4.14m)
Overall Machine Length (E)	204.75" (5.20m)	318.13" (8.08m)	360.25" (9.15m)	
Length Between End Frames (F)	196" (4.98m)	309.38" (7.86m)	351.50" (8.93m)	
Suggested Cutting Table Slab Height	30" (0.76m)			
Maximum Traverse Speed	2,100 IPM (53.3mpm)			
Maximum Number of Stations	2 tools (plasma torch, oxy-fuel torch or air scribe marker)			
Maximum Number of Plasma Stations	1			
Recommended Plasma Systems	Hypertherm® Powermax series, HSD 130™, MAXPRO200™, HPR130XD™, HPR260XD™, HPR400XD™			
Maximum Number of Oxy-Fuel Stations	1			
Machine Input Power	200-240 VAC 1P 50/60 Hz Dedicated Circuit			

\*\*\*Specifications are subject to change

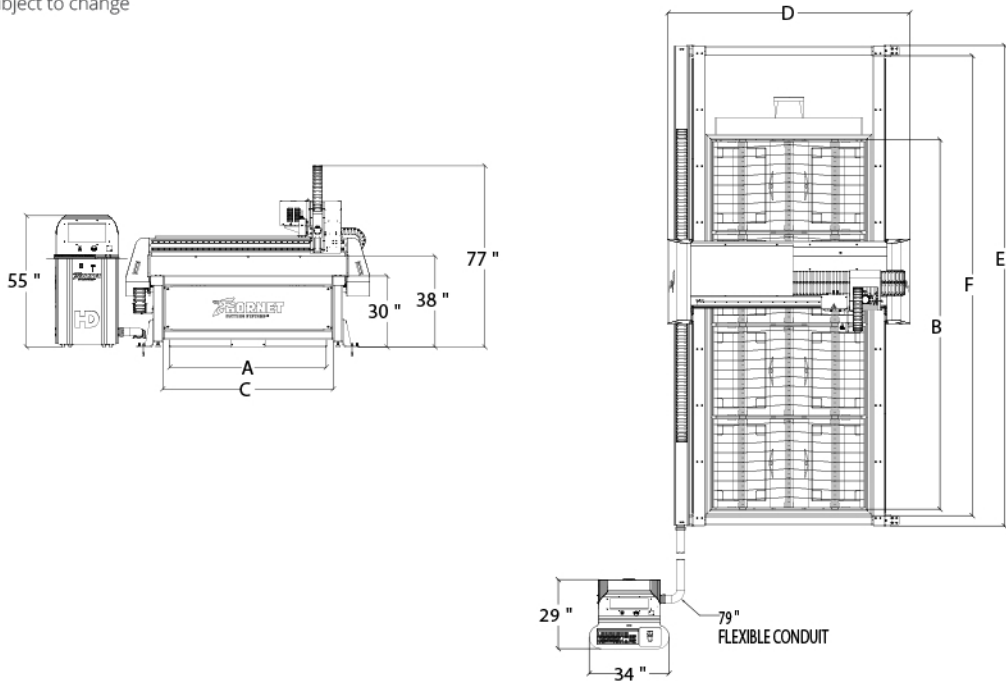

Visit [www.HornetCS.com](http://www.HornetCS.com) or call 1-844-209-5552 to request a quote.



POWERED BY **Hypertherm**

430 W. Clay | Valley Center, KS 67147  
 TF: 844-209-5552 | P: 316-755-3683  
 F: 316-755-1675 | [Info@HornetCS.com](mailto:Info@HornetCS.com)  
[www.HornetCS.com](http://www.HornetCS.com)

A Service-Disabled Veteran-Owned Small Business  
 ISOQAR Quality Assured ISO 9001 Certificate # 14037ASR001