

FlexDrill

GRD Series

MILL
DRILL
TAP
COUNTERSINK
HELICAL MILL
CHAMFER
BEVEL
BORE

Rapid Drill | Mill | Tap

The GRD Series

Work Envelope

X Axis: 10' - 30'
Y Axis: 4' - 6'

Customizable by size, capacities, and accessories

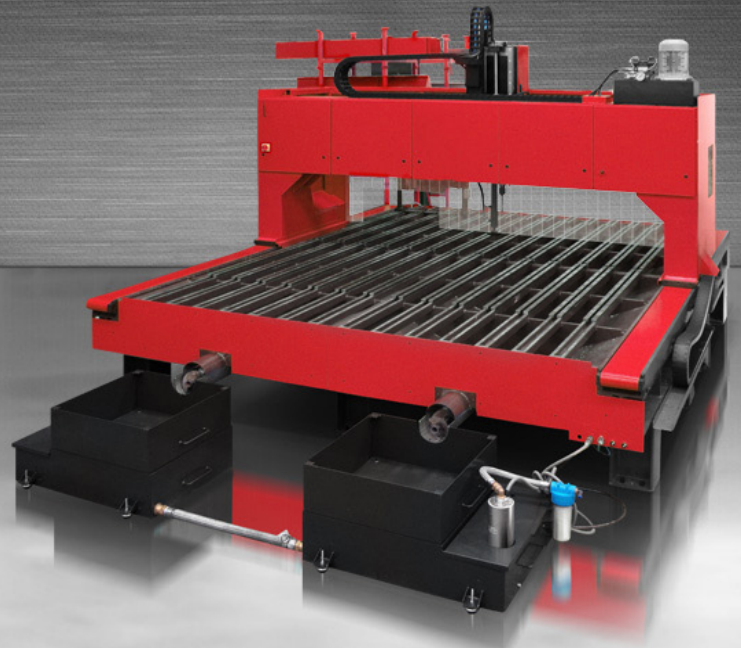

Custom length beds available - Call for Quote.

1-800-837-2503

www.flexdrillcnc.com

GRD Specifications

Work Envelope

Model Number	GRD 10-04	GRD 15-04	GRD 20-04	GRD10-06	GRD 15-06	GRD 20-06
Machine Bed Size (X,Y)	10' X 4'	15' X 4'	20' X 4'	10' X 6'	15' X 6'	20' X 6'
Price	\$161,995	\$181,995	\$198,995	\$166,995	\$186,995	\$205,995

Spindle and Capabilities

Spindle RPM	6000 rpm	4000 rpm	3000 rpm	2400 rpm	2000 rpm
Max Torque	52 ft/lbs	64 ft/lbs	83 ft/lbs	105 ft/lbs	126 ft/lbs
Max Torque (With 18 hp upgrade)	74 ft/lbs	92 ft/lbs	123 ft/lbs	155 ft/lbs	184 ft/lbs
Max Torque (With Optional ZF Gearbox)		368 ft/lbs			

Feed Rates

Max Feed Rate (X)	1181 in/min
Max Feed Rate (Y)	984 in/min
Max Feed Rate (Z)	165 in/min
Z Axis Travel	19.5"
Spindle Nose to Table	CT40: 5.5" - 25" / CT50: 3.1" - 22.8"
Spindle Taper	CT or BT: 40/50

FlexDrill CNC

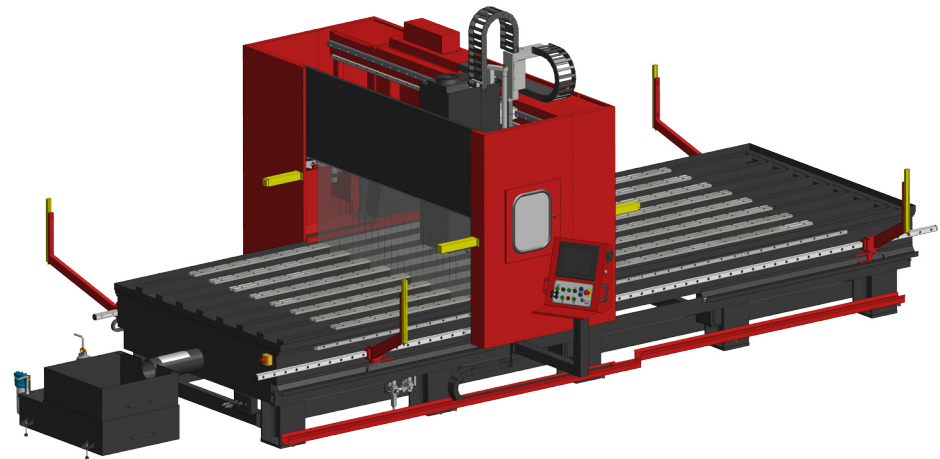

Accessories

	Accessories	Price
1	ZF Gearbox with two speed ranges 50 to 1000 and 1000 to 4000	\$19,995
2	Cross work area safety light barrier	\$1,752
3	12-Station Automatic Tool Changer	\$13,945
4	10-Station Fixed Tool Changer	\$6,945
5	Through spindle coolant	\$4,495
6	External Control Panel on linear guide	\$4,295
7	Automatic micro-spray lubrication system for drilling in profiles	\$2,595
8	Automatic paste spray system for flow drilling	\$3,245
9	Automatic oil spray system for roll-tap operations	\$3,245
10	Renishaw Probe System: model RMP 40	\$13,795
11	Z-Reader Probe for flow drilling and chamfering jobs mechanical probe checks material surface height for automatic Z correction	\$4,595
12	CT50 Spindle	\$11,495
13	10 Station Automatic Tool Changer: CT 50	\$18,445
14	7 Station Fixed Tool Changer: CT 50	\$9,245
15	18hp spindle drive motor (instead of 12hp)	\$5,195
16	Write programs on an external Laptop with our Drillwin NJ13 - 2017	\$1,995
17	Drillcam 2017 Read any kind of 2D or 3D drawing for easy G-Code Programming	\$7,900

	GRD 4TH AXIS	
18	4th Axis Model D-250 -10" Platter	\$16,995
19	Jaw Chuck: 3 Jaws	\$1,395
20	Table with linear guides for model D-250: Positioning in Y Axis	\$5,795
21	Adjustable Manual Tail Stock	\$2,245
22	Adjustable Pneumatic Vice for round tubes	\$2,495
23	Universal Pneumatic Vice Width: 8" Clamping Range: 23.2"	\$1,395
24	Insert for multi-vice unit (for FlexDrill's universal pneumatic vice) For clamping 4 workpieces: min .59" / max.2.36" Equipping with 4 clamping jaws with cup-springs to compensate for workpiece tolerances	\$695

Standard Features Include: GRD mobile light-curtain barriers, Frame with chip conveyor and T-slotted table, Flood coolant - pump and tank, and Automatic tool calibrator

FlexDrill

MILL
DRILL
TAP
COUNTERSINK
HELICAL MILL
CHAMFER
BEVEL
BORE

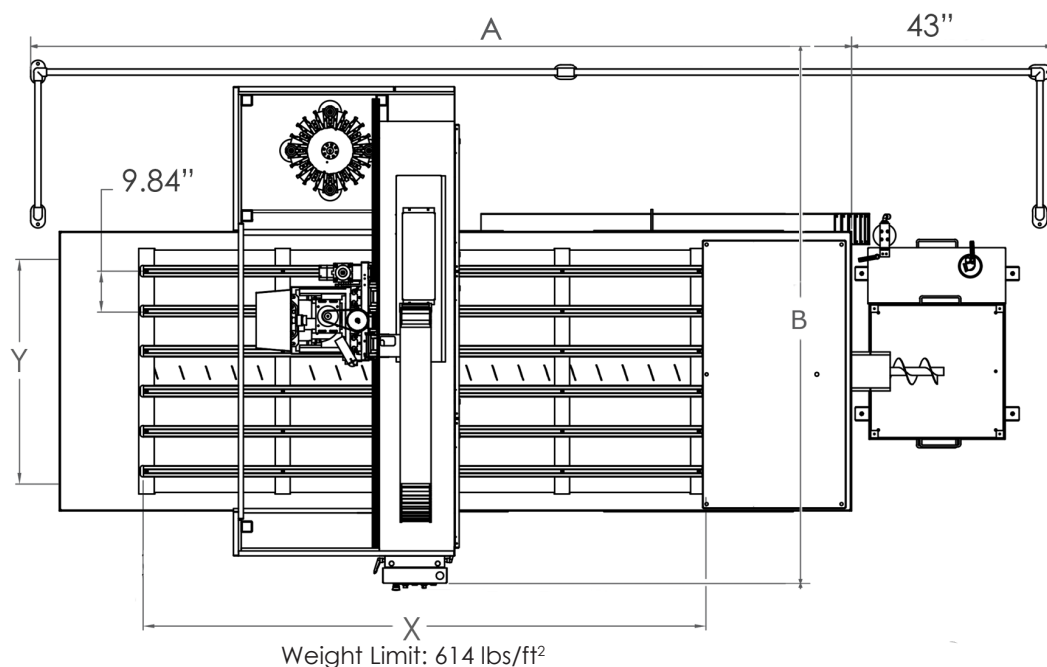
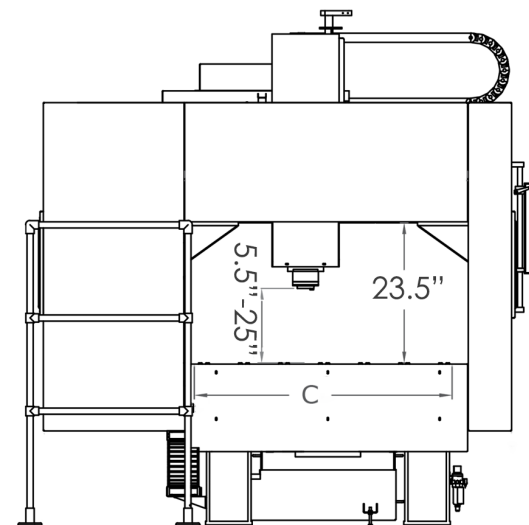
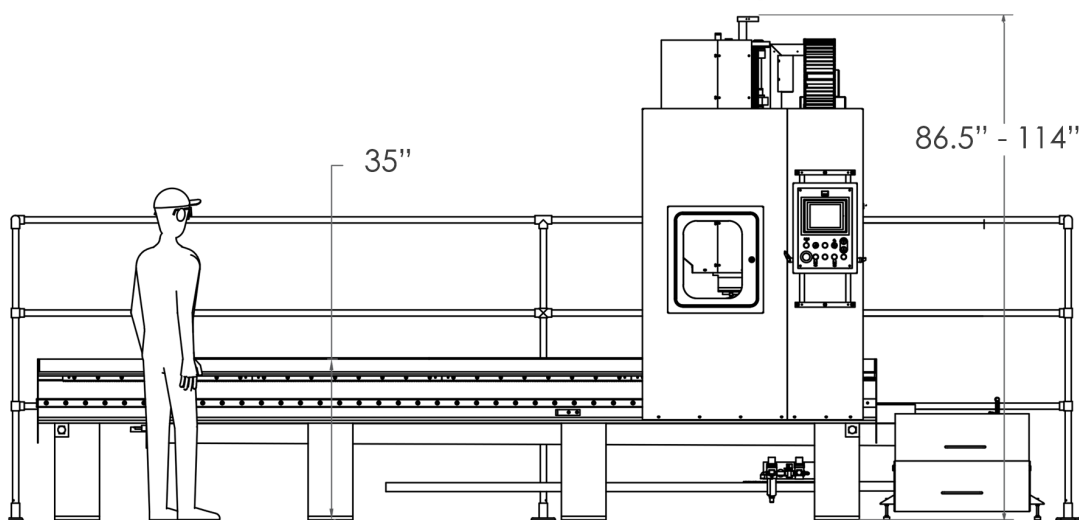

Weight Limit: 614 lbs/ft²

GRD Series Dimensions

A	15'	20'	25'	30'	35'
X	10'	15'	20'	25'	30'
Y	4' / 6'				
B	9.25' / 11'				

Repeatability Accuracy:

X: +/- .001

Y: +/- .0007

Z: +/- .0005

Position Accuracy:

X: +/- 0.002

Y: +/- 0.0015

Z: +/- 0.001