

# ADVANTAGE

YOUR FORMING ADVANTAGE



**Accurpress**

[www.accurpress.com](http://www.accurpress.com)

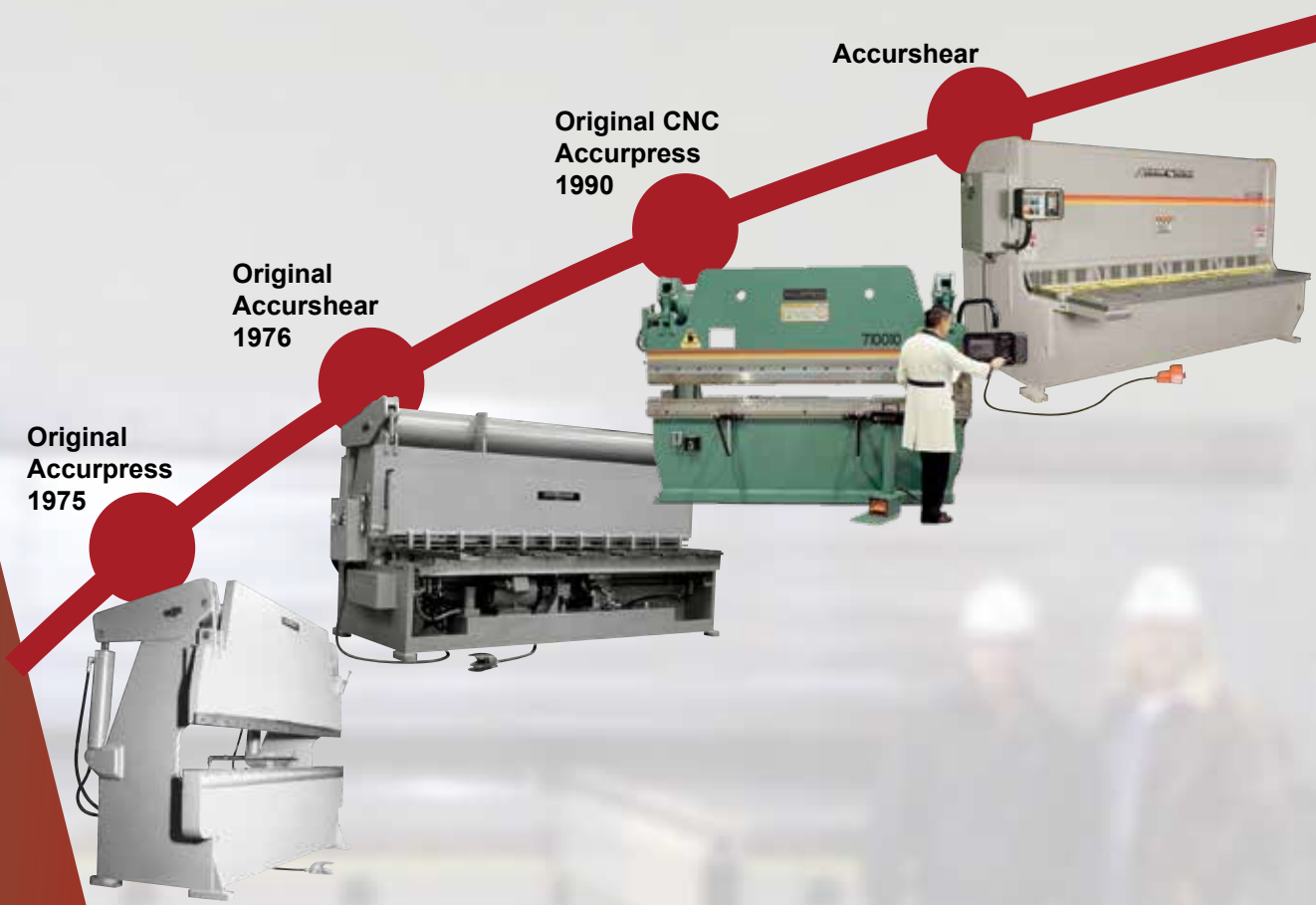

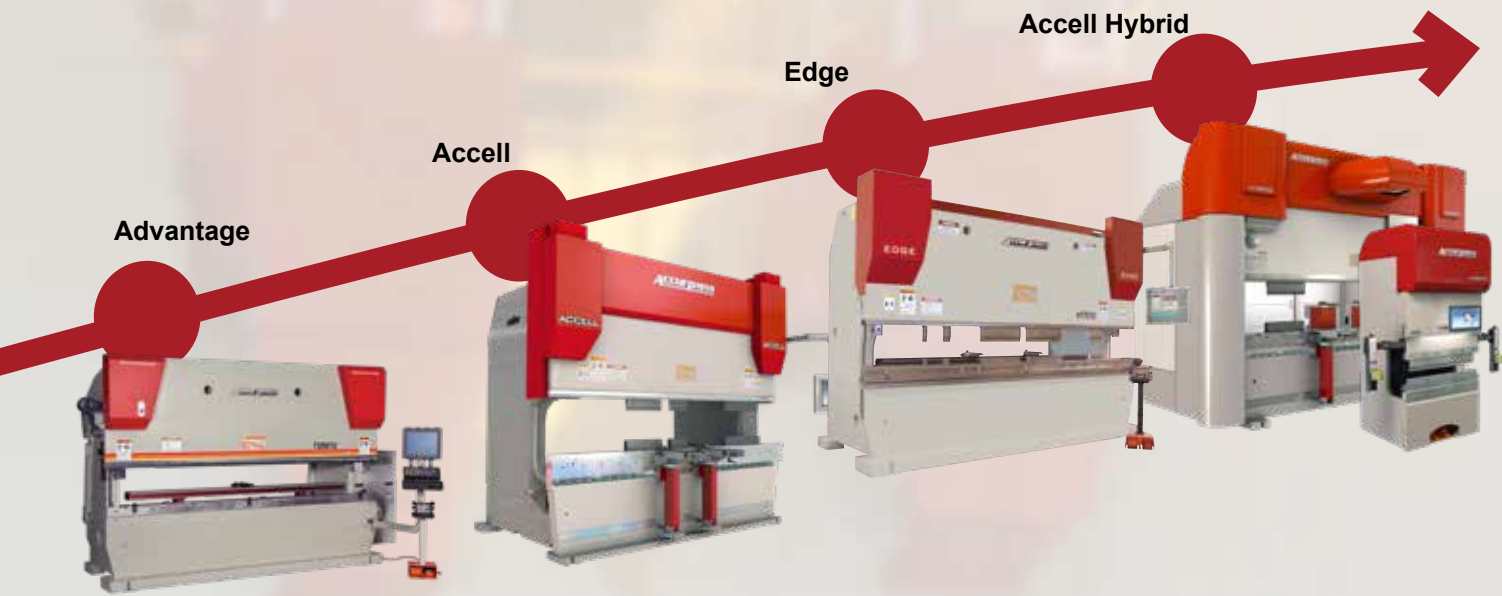

# ABOUT US

With over 40 years in the marketplace, Accurpress continues to build on its tested history to manufacture an innovative and complete line of press brakes and shears for every bending and shearing application. Proudly North American made, Accurpress leads the way with high tonnage machines, revolutionary pole bending technologies, tandem machines, and robot automation. With over 19,000 machines sold to thousands of satisfied customers, Accurpress continues to build press brakes and shears to meet the demands of today's manufacturing environments.

**Steve Hilton**  
President

"While 40 years has brought huge changes to the machine tool industry, all of us at Accurpress continue to stand firm on the original foundation of quality that the company was built on. Every Accurpress machine, including the one you'll buy, is made with 100% of our best efforts. Our business depends on it and so does yours."

# THE ACCURPRESS ADVANTAGE LINEUP

Accurpress has thousands of machines installed in fabrication shops all across North America. These machines have the proven, rugged and endlessly reliable Rocker Arm Design that has met and exceeded metal manufacturing demands for decades.

25 TON

60-250 TON



Sold and Serviced via first-class machine tool dealerships across Canada, United States and Mexico. Visit [www accurpress.com](http://www accurpress.com) for detailed information about the Accurpress product and the Accurpress Dealer in your territory.

## 320-500 TON



Our 40 years of design experience guarantees that these machines will stand up to your forming challenges. Our wide range of models, sizes and customization options means we can build a machine that will be perfect for your specific application.

## ACCURPRESS ROCKER

### Features Available For All Models

All Accurpress press brakes are designed and built to high standards of lifetime durability and precision accuracy, backed with a minimum two-year warranty.

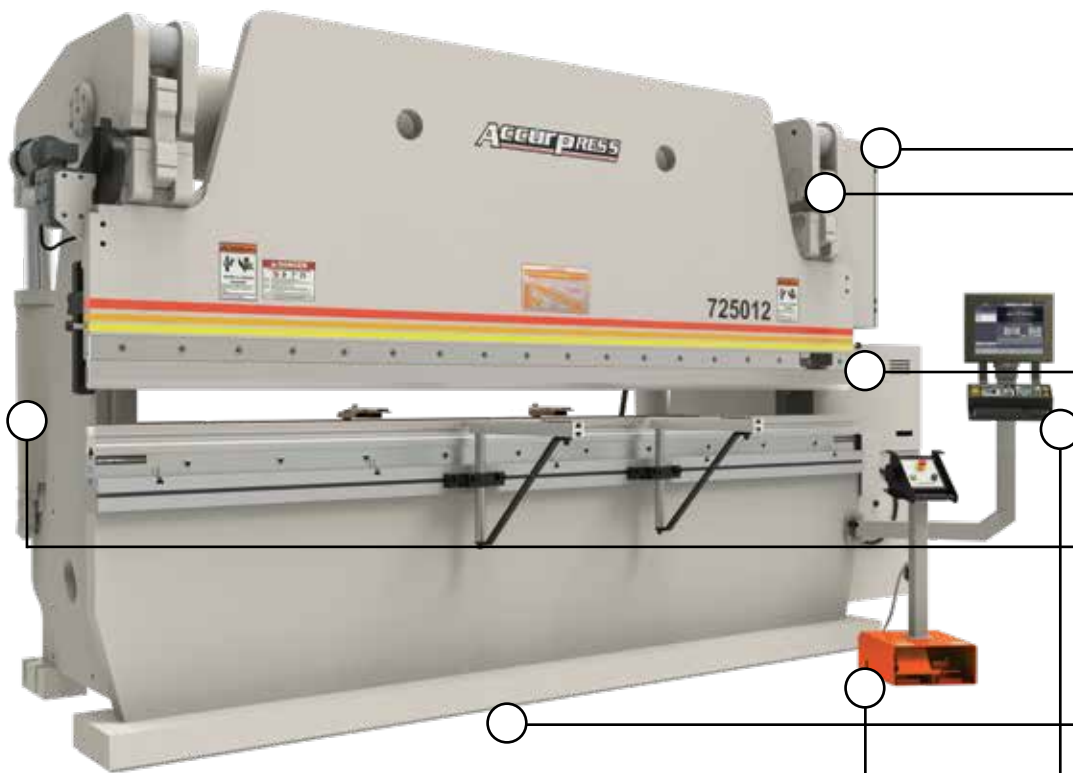

#### FOOTSWITCH

The footswitch operation station incorporates features that include dual palm buttons, emergency stop, and ram tilt selector switch.

#### POWER RAM TILT

The power ram tilt adjustment optimizes ram trim to match various tooling characteristics, or for doing fade out work. It's easily adjusted via push buttons located on the operator control station. An eccentric shaft running through the left side connecting rod of the Accurpress will rotate when powered, and will tilt the ram to the desired location.

**UNIQUE DESIGN**

This basic design consisting of side frames, bed assembly, ram, double rocker arm assembly and torque tube has been tried and proven in a vast number of shops ranging from high precision sheet metal to heavy fabrication applications. Rear mounted cylinders attached to the double rocker arm assembly allows for a compact frame with minimal side frame stress.

**ADAPTABLE DESIGN**

Our design is adaptable to specific application requirements such as special bed and ram machining to suit tooling requirements, ram clamping options, higher ram open heights, punching applications and concentrated high tonnage loads.

**MAINTENANCE FREE BEARINGS**

Pivot points of the rocker assembly utilize high quality, maintenance free, self-lubricating plain bearings, and self-aligning spherical bearings. Bearing types are sized in relation to the model tonnage and are suited to high loads and oscillating motion of the press brake. Decades of maintenance free bearing use can be expected.

**FLUSH FLOOR MOUNT**

Accurpress manufactures models up to and including 500 ton capacities that are a flush floor mount design. The heavy I-beam design on the larger tonnage models provides the structural integrity to achieve excellent forming quality, while eliminating the expense of special foundation requirements for below-the-floor bed members. As is the case with all forming jobs, deflections will occur that will necessitate either a crowning die holder or shimming procedures for optimal forming quality. The specification chart on page 23 should be referenced to validate all Accurpress models that are flush floor mount. Longer bed/ram length models will require below-floor-beds in order to stay within the engineering deflection criteria that Accurpress adheres to.

**WORLD-RENOWNED COMPONENTS**

Accurpress has long established relationships with quality vendors. All areas of the Accurpress are built to high standards with easily replaced parts, designed with common sense in mind. Side-mounted hydraulics allow easy access to the back of the machine for gauging and fixtures, incorporating a low-noise submersed piston or vane pump combined with directional valves.

## ADVANTAGE UPGRADE PACKAGE

The ADVANTAGE package is available on all Accurpress models up to 320 ton unit size only.

Dual Ram Encoders are a standard feature on Accurpress models 400 ton and larger.





## RAM TILT INDICATOR

Attractive front covers complete with a Dial Indicator measures the applied ram tilt adjustment.

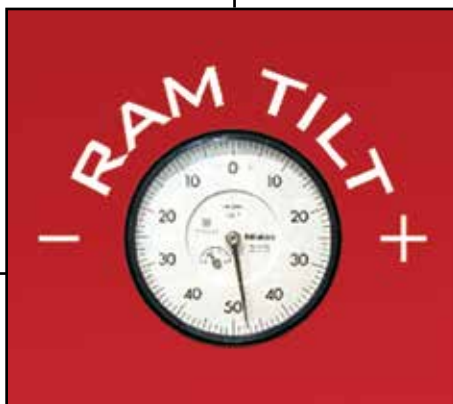

## PROPORTIONAL VALVE TECHNOLOGY

Advantage models feature proportional hydraulic valve technology for enhanced ram position repeatability.

## DUAL RAM FEEDBACK SYSTEM

The Dual Ram Feedback system is an excellent and recommended option in off-center or stage bending applications. Encoders are mounted at each end of the Accurpress to measure the ram position during the bending cycle, and make the necessary adjustments when unequal forces are applied across the full length.



# ACCURPRESS CONTROLS

## ETS200 CONTROL



### FEATURES:

- Controls Ram and Backgauge X Axis
- 4 Line LCD Display
- 100 On-Board Programs
- 100 On-Board Programs
- 9 Steps per Program
- Easily Set and Save Ram Positions
- Tonnage Mode Programming

## UPGRADE TO THE ETS3000 CONTROL



- Touchscreen Control
- 2D Graphical Mode
- Store Thousands of Bend Programs
- Auto Bend Sequence
- Auto Tool Select
- 17" Screen
- Create Custom Tools
- Teach Mode
- Maintains ETS200 Control Panel
- Optional Offline Programming Packages

### ETS200 AND 3000 FEATURES AT A GLANCE

	ETS200	ETS3000
X-axis	✓	✓
Y-axis	✓	✓
R-axis	—	Optional
Z1/Z2-axes	—	Optional
Pendant mounted	✓	✓
Crowning interface	—	Optional
Graphic display	—	✓
Tool library	—	✓
Information display	4 line LCD	17" TFT
On-board programs	100	3000
Steps per program	9	50
Off-line programming	—	Unlimited

## ETS3000 CONTROL: 3D PROGRAMMING

A 3D offline programming package is available that is created in the Accurpress Vision Control, but may be imported and run on the ETS3000 Control. (Reference [www.accurpress.com](http://www.accurpress.com) for Vision Control for details.) Third Party software packages such as: Radan, Metamation, and SigmaNEST are also fully compatible with the ETS3000 control.



### VISION 3D

Working with Solidworks or Inventor, Vision 3D lets you import part models into Vision for full 3D programming, bend visualization and dynamic viewing during the forming process.

### FEATURES:

#### USE VISION IN YOUR PART MODELS

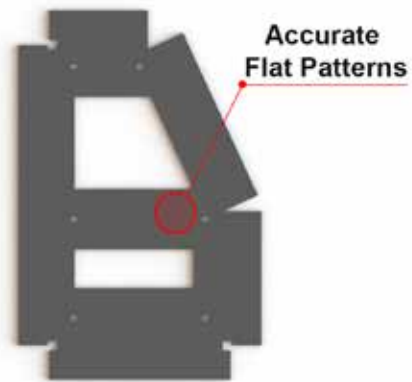
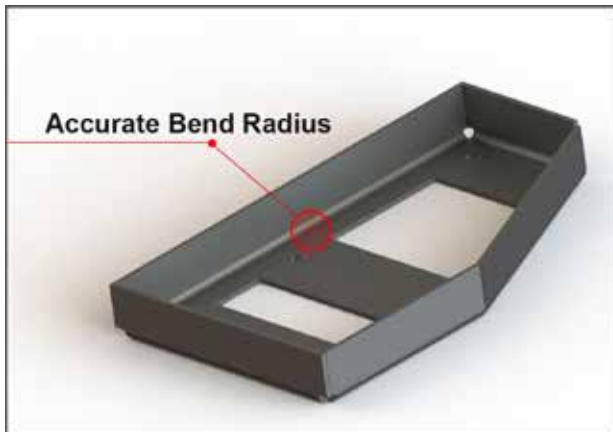

- Dynamic 3D Bend Simulation

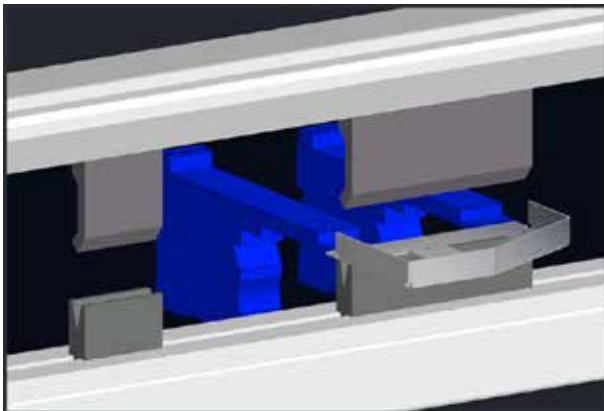

- Run 3D programs on the ETS3000



## PREMIUM BACKGAUGE OPTIONS

The Premium backgauge is ideal for the Accurpress Advantage models, built with large section extrusions and roller carriage castings for strength, accuracy and decades of usage. This gauge comes with power X-axis, manual R and Z1/Z2. Optional power R and Z1/Z2 are available or may be easily retrofitted at a later date. (Confirm with Accurpress Engineering the gauge bar length for models over 20' in length.)

### PREMIUM SPECIFICATIONS

	X Axis	R Axis	Z1/Z2 Axis
Axis Travel	24" - 39" 609.6 - 990.6 mm	10" 254 mm	Distance between side frames minus 10"
Positioning Speed	900 ipm	900 ipm	900 ipm
Position Repeatability	+/- 0.001"	+/- 0.001"	+/- 0.003"
Holding Force	750 lbs		

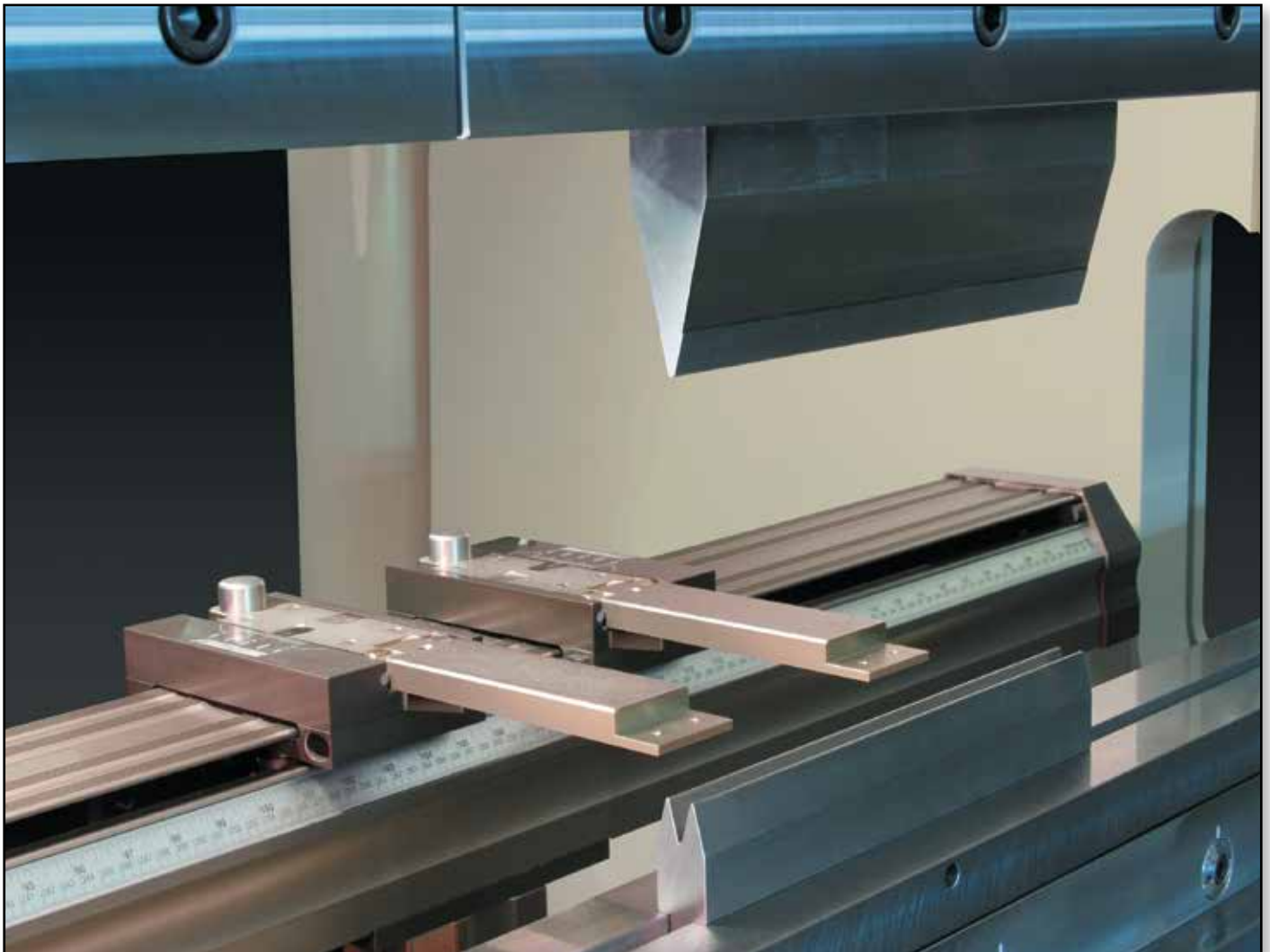

# PREMIUM FINGERS

## GAUGING POSITIONS

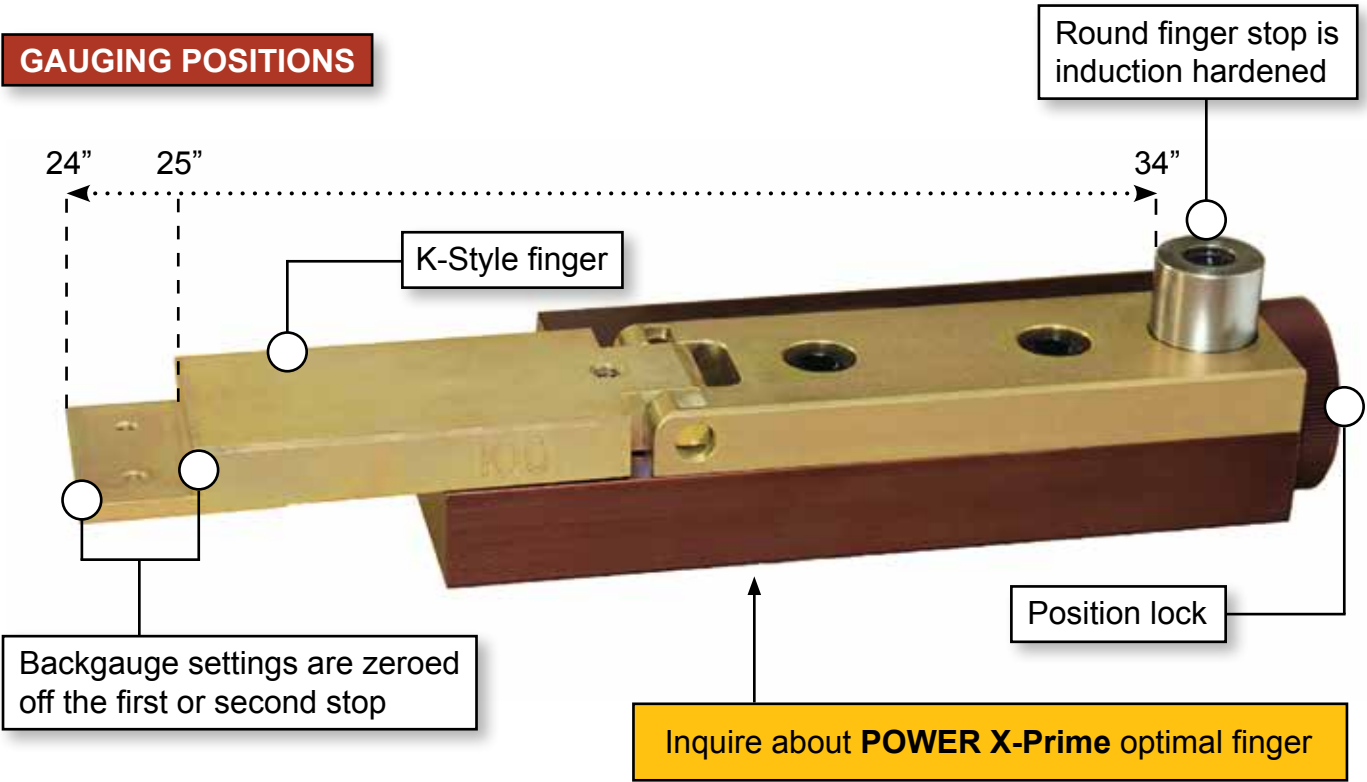

## FLIP FINGER



## SNAP-CHANGE



## OPTIONAL MANUAL X-PRIME



Reference the **Accurpress High Tonnage** brochure for detailed information on the Titan backgauge which is recommended on the 740020 — 750024 models.

## ADDITIONAL OPTIONS

### ADJUSTABLE SPEED CONTROL

Adjustable bending speed is an excellent feature to reduce whip-up of larger sheets during the forming application.

Adjustment of the pressing speed is accomplished via a rotary hand dial located on the hydraulic unit.

The fast approach and fast return speeds are not affected with this adjustment.

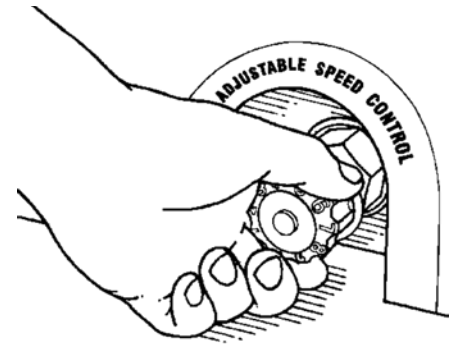

### HARDENED RAM CLAMP BARS



Accurpress offers hardened ram clamp bars for protection against damage to the under surface of the ram, particularly when high concentrated loads are applied using short sections of male punches.

These clamp bars are made from Alloy 4140 steel and are mounted on the front and back of the ram. This is a standard feature on Accurpress models 500 tons and larger, but is a recommended option on lighter tonnage machines where short male punches are being utilized.

### SHEET SUPPORT ARMS

A) Front Swing Stock Arms are available in 24", 36" and 48" lengths for material support and gauging techniques. They come complete with T-slots and disappearing stops. The arms bolt to the drilled and tapped holes or the optional T-slots on the front face of the bed. These support arms can be vertically adjusted to the corresponding tooling height.

B) 24" Front Support Fixtures complete with a built-in protractor and squaring capabilities are an excellent accessory, providing optimal flexibility with a convenient built-in protractor, squaring capability and disappearing stops. The arms are mounted to a precision guide rail to facilitate ease of left-right motion and are adjusted vertically via a foot disc for accurate height adjustments.

C) 36" Heavy Duty Front Support Fixtures with a weight capacity of 900 lbs. per arm are also available and recommended for Accurpress models 7320xx and larger. These heavy arms mount the same way as the smaller units on a precision guide rail for ease of left-right motion and include all the attractive features to provide maximum versatility for plate support and positioning for bending purposes.



## PUNCHING APPLICATIONS

The Accurpress is an ideal machine for punching applications. We offer removable angle plates in modular lengths measuring 5-1/2" x 5-1/2" that bolt to the ram and bed. To offer greater flexibility, you may choose angle plates for the ram only at the desired length and request the fixed bed cap be widened to correspond to the overall ram angle width.

To maximize the longevity of the Accurpress subjected to punching shock loads, we recommend that the option for the remote electrical/hydraulic power unit be ordered to isolate the components. This option relocates the main electrical enclosure and hydraulic reservoir from the Accurpress frame to avoid the inherent punching forces. In addition, it is also recommended that the Dual Ram Feedback option be purchased to provide optimal ram balance when punching is staggered along the length of the Accurpress.

## HIGH SPEED HYDRAULIC PACKAGES

Higher production applications may require faster ram cycle times. Accurpress offers packages with additional horsepower and pump volumes that provide increases in the ram fast down and return speeds of approximately 30% to 50%. Included in the High Speed option is the Adjustable Speed Control feature.

## PALM BUTTONS MOUNTED ON THE RAM

Palm buttons are included as a standard feature with every Accurpress, and are mounted on the ETS pedestal. Optionally, palm buttons complete with an emergency stop button may be mounted on the ram in lieu of the stand. For two person operation, additional palm buttons are available—either mounted on the pedestal or on the ram.

## MACHINING OPTIONS

Accurpress offers a variety of machining options such as a 3/4" wide x 1" deep groove in the center of the bed, T-slot running left-right in the front face of the bed, ram machined for dual safety tang and/or additional machined features on request.

## SECOND FOOT SWITCH

An additional footswitch is available to provide optimal safe-operating conditions, especially in applications where larger and longer sheets are being formed that require two machine operators. Both foot pedals must be depressed to activate the ram down motion, however, the ram will automatically return to the up position if one foot pedal is released. A selector switch is provided to allow for either single or dual operation. Accurpress also offers a programmable dual footswitch option is also available for Accurpress models ordered with the ETS3000 control.

## RAM AND BED HORN EXTENSIONS

Horn extensions are necessary in applications requiring part forming at the end(s) of the press brake for wrap-around purposes. Accurpress offers horn extensions, generally in 1' or 2' lengths, but may also review and design up to 3' lengths for specialized applications.

The bed/ram horn extensions may be purchased for one end only or for both ends of the Accurpress.

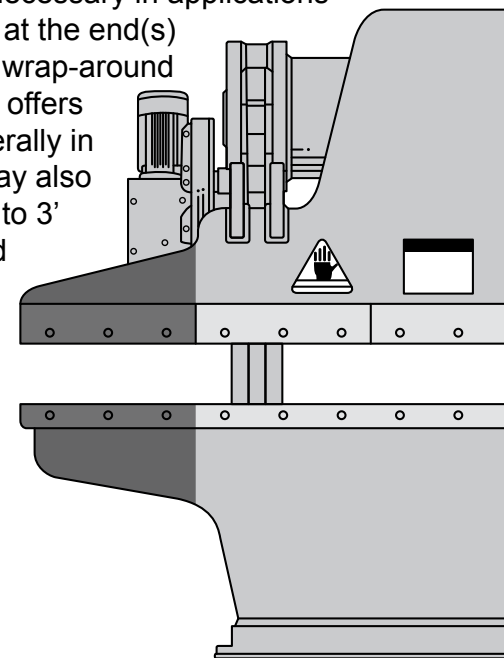

## SHEET FOLLOWER SYSTEM

To meet the ever changing and challenging demands of the precision sheet metal and heavy fabrication industry, Accurpress has designed and manufactured an Automatic Sheet Following system, the latest in technology offering finesse and high quality.

### MECHANICS

The Sheet Follower table is guided by a quadrant track on grooved roller bearings. The table trajectory is a circular arc which follows the bending motion of the part being formed.

Heavy duty load capacity of 500 lbs direct load per follower table.

The Sheet Follower(s) is easily positioned left to right via a linear bearing/rail that is attached directly to the press brake bed.



### PARKING STATION

Sheet Followers can be moved off to the side when not in use, providing full access to the front of the machine.

### FAST AND QUIET

This system is fast and quiet, driven by a high torque brushless DC servomotor and drive system for table rotation.

### SAFETY BRAKE

Each Sheet Follower is equipped with a brake to maintain the Sheet Follower position in the event of a sudden power failure.



## ETS3000 INTEGRATION

The Sheet Follower system is fully integrated to the Accurpress ETS3000 control and is operational in graphics or angle text modes. The follower synchronizes with the ram motion during the bending process, up to the maximum 24 IPM bending speed, where female die openings of 1" or larger are being used. When utilizing smaller female die openings a reduction in the press brake bending speed is necessary. The descent speed is also adjustable as a percentage of maximum descent speed set in the machine parameters. The machine operator has the option of programming both Sheet Followers to be on/off per step or only one of the two to be in operation per step.



## TABLE DIMENSIONS

Each Sheet Follower table is 40" in length and 16" in width. A 22" extension is available as an optional accessory.

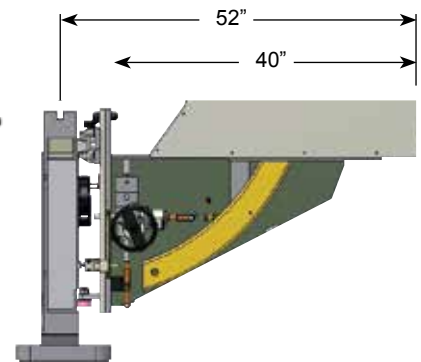

## RETURN CLEARANCE

The table front edge is set back from the lower die to permit parts with short return flange clearance. Parts with long return bends will necessitate moving the Sheet Follower away from the end of the part or to the parking position.

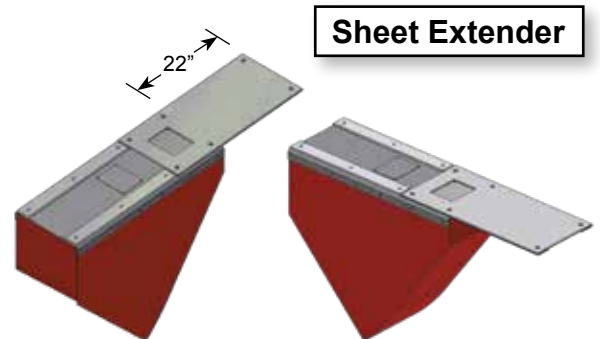

## RAM CLAMPING AND CROWNING OPTIONS

We offer world renowned WILA Clamping systems fully integrated into the Accurpress ram and hydraulics.

These precision systems clamp and seat WILA tooling—American or New Standard—with the simple push of a button. Other brands of American styles of tooling may be used but without the automatic seating feature.

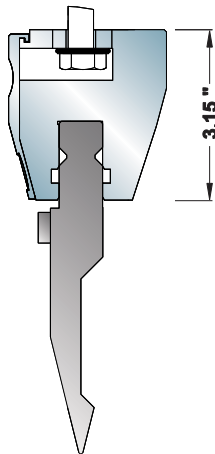
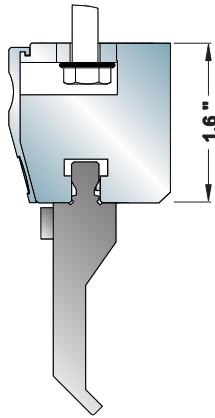
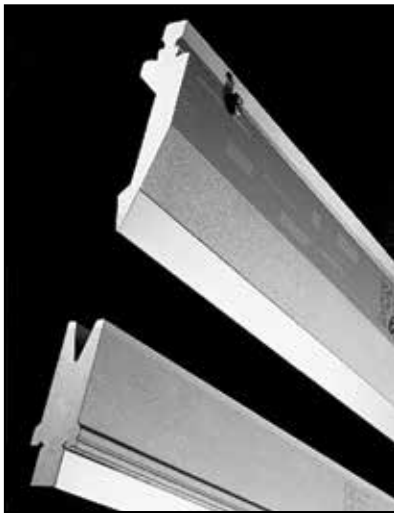

Eliminate shimming of press brake tooling and reduce costly set up time with the Accurcrown Die Holder system, which may be adjusted manually or power interfaced to the ETS3000 CNC system.

## SYSTEMS IN TWO SIZES

- 3.75" wide x 3.75" high:  
- Suitable for 4-way block sizes up to 3.50"

- 6.0" wide x 3.75" high:  
- Suitable for 4-way block sizes up to 5.75"

## LOCALIZED DIAL ADJUSTMENTS AT 8" CENTERS



## OPTIONAL 4-WAY DIE FIXTURE



4-way die fixtures are bolted to the top of the crowning unit, and rotate to suit various 4-way tooling sizes.

## DIGITAL COUNTER

Rotating the handle on the manual holder adjusts the crown from the center out. An LED counter displays the exact crown in thousandths of an inch.

## CUSTOM TOOLING

Accurpress offers custom tooling applications—tested and proven in our factory. Our dedicated tooling specialists will work with you to engineer the ideal solution for your special forming requirements.



Roto Rib Die

Refer to our **Accurpress Tooling Catalog** for detailed information.

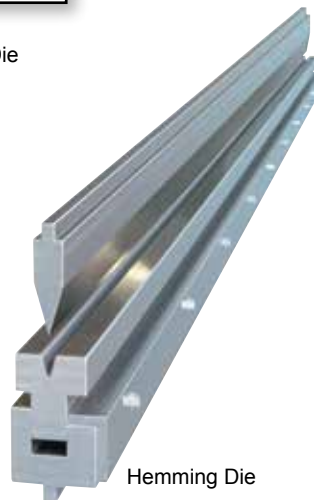

Hemming Die

Easy Tab

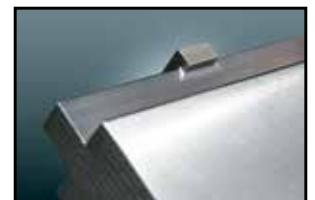

## OPERATOR GUARDING SYSTEMS

### LAZERSAFE SENTINEL

Lazersafe Sentinel is a Safety System offered on the Accurpress models that incorporates a continuous dual beam laser field protection zone directly below the punch tip. The Accurpress will immediately stop if any obstruction is detected when the ram is in motion. This system is most efficient up to 32' ram/bed lengths.



### LAZERSAFE SENTINEL PLUS

The Lazersafe Plus includes a dual beam system with a camera as a receiver that recognizes and monitors the silhouette of the punch. The Plus has the added benefit of allowing the ram to operate in fast speeds closer to the pinch point. This system is most efficient up to 18' ram/bed lengths. A Sentinel Plus HL system is available for Accurpress models 20' and longer in length.

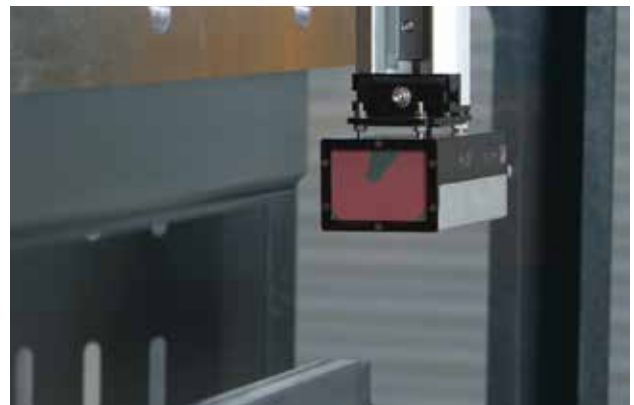

### REAR GUARDING



At Accurpress, we strive to provide our customers with guarding systems to protect your workforce from accidents, while enhancing your equipment appearance. Accurpress modular rear guarding is available for all models. Upon entry into the hazardous area, all motion is halted to ensure safe access for operators or maintenance personnel.

Our design is engineered to comply with the CSA standard for safeguarding devices when used in conjunction with either Light Curtain or Lazersafe guarding systems.

## ISB LIGHT CURTAIN

The ISB Light Curtain is a solid-state electro-optical switch which produces and checks an invisible network of closely spaced, pulsed, infrared light beams between separate transmitter and receiver columns. As long as conditions are normal and all beams are received, the output relay contacts remain closed. If any beam is interrupted, the ram will stop immediately.

This system's control offers a programmable beam blank-out feature with job storage memory. This unique concept pioneered by ISB can learn the flange pattern and automatically create a window exactly the size required and only during a specific cycle. The opening may change from stroke to stroke, automatically, determined by the processor, not your operator or setup personnel. No decisions... No errors... No complications...

ISB Light Curtains are available in 18", 24" and 30" heights. It's simple, fast, reliable, and no extra set-up time is required. Press brakes will safely operate at their current fast speed range.



See [www.isblite.com](http://www.isblite.com) for further details.

## STI LIGHT CURTAIN



See [automation.omron.com](http://automation.omron.com) for further details.

In operation, the STI Light Curtain extends a definitive 20" high "curtain of light" in front of the hazardous area. If a worker's hand breaks the "curtain," a signal is sent to the stop circuit on the machine. The curtain offers floating blanking and exact channel select to allow the operator versatility with various bending operations.

Additionally, the curtain allows for muting in the slow pressing speed. External limit switches are adjusted for the appropriate muting location. In order to meet the above safety standards, the limit switches are mounted inside a lockable enclosure. Mounting fixtures are supplied with the light curtain which the operator must adjust to the appropriate distance from the bending point.

## Be in Compliance with OSHA and ANSI Regulations

In the manufacturing of all Accurpress equipment, safety is of high importance. However, a press brake can only be safe when operated properly in accordance with the machine owner's manual, and the specific dictates of the applicable OSHA and ANSI regulations. Incorporated into the design stage are a number of built-in features that serve to protect both the operator and the equipment if used correctly and safely according to the instructions provided with each individual machine. The operational controls have been created to maximize efficiency if used in accordance with the applicable ANSI and OSHA regulations and in conjunction with adequate point of operation guarding chosen by the owner/user for the specific job action.

Clear, concise, strategically placed decals serve as a constant reminder of specific hazards and steps to be taken to avoid needless injury. Within the owner's manuals are sections that highlight safety concerns. Owners and operators of Accurpress equipment must understand and comply with their responsibilities in regard to the regulations for the use and operation of press brakes and shears.

# ADVANTAGE SPECIFICATIONS

MODEL NUMBER	TONS	A LENGTH OF BED (INCHES)	B DISTANCE BETWEEN FRAMES (INCHES)	BED HEIGHT (INCHES)	BED CAP WIDTH (INCHES)	BED DEPTH BELOW FLOOR (INCHES)	C D E APPROX. OVERALL DIMENSIONS (INCHES)			LENGTH OF RAM STROKE (INCHES)	F RAM OPEN HEIGHT (INCHES)	RAM CLOSED HEIGHT (INCHES)	G THROAT DEPTH (INCHES)	APPROX. SPEEDS (INCHES/MINUTE)			CYCLES PER MINUTE		APPROX. MOTOR HP	APPROX. SHIPPING WEIGHT (Lb)
							LENGTH (INCHES)	DEPTH (INCHES)	HEIGHT (INCHES)					FAST APPROACH	SLOW BEND	FAST RETURN	2.5" Fast Approach	0.5" Slow Bend		
7254	25	51	51	34	2	—	61	44	66	6	12	6	—	200	28	300	25	—	7.5	4,150
7606	60	72	52	34	3	—	88	48	74	8	14	6	8	130	24	260	22	28	10	6,000
7608	60	96	76	34	3	—	112	48	74	8	14	6	8	130	24	260	22	28	10	8,000
76010	60	120	100	34	3	—	136	48	76	8	14	6	8	130	24	260	22	28	10	10,000
76012	60	144	124	34	3	—	160	48	76	8	14	6	8	130	24	260	22	28	10	12,000
71006	100	72	52	34	3.5	—	88	52	80	8	14	6	10	115	24	200	16	23	10	10,000
71008	100	96	76	34	3.5	—	112	52	82	8	14	6	10	115	24	200	16	23	10	12,000
710010	100	120	100	34	3.5	—	136	52	84	8	14	6	10	115	24	200	16	23	10	14,000
710012	100	144	124	34	3.5	—	160	52	86	8	14	6	10	115	24	200	16	23	10	16,000
71306	130	72	52	34	4.0	—	88	56	80	8	14	6	10	115	24	180	15	20	15	11,000
71308	130	96	76	34	4.0	—	119	56	82	8	14	6	10	115	24	180	15	20	15	13,000
713010	130	120	100	34	4.0	—	143	56	84	8	14	6	10	115	24	180	15	20	15	15,000
713012	130	144	124	34	4.0	—	167	56	86	8	14	6	10	115	24	180	15	20	15	17,000
713014	130	168	148	34	4.0	—	191	56	92	8	14	6	10	115	24	180	15	20	15	21,000
713016	130	192	172	34	6	—	196	56	94	8	14	6	10	115	24	180	15	20	15	25,000
71758	175	96	76	34	6	—	130	60	84	8	14	6	10	90	24	180	15	20	20	17,000
717510	175	120	100	34	6	—	154	60	86	8	14	6	10	90	24	180	15	20	20	20,000
717512	175	144	124	34	6	—	178	60	88	8	14	6	10	90	24	180	15	20	20	23,000
717514	175	168	148	34	6	—	202	60	94	8	14	6	10	90	24	180	15	20	20	26,000
717516	175	192	172	36	6	—	226	60	96	8	14	6	10	90	24	180	15	20	20	32,000
717520	175	240	201	36	12	—	274	60	104	8	14	6	10	90	24	180	15	20	20	54,000
72508	250	96	76	36	6	—	130	64	98	8	16	8	10	65	21	140	11	15	20	20,000
725010	250	120	100	36	6	—	154	64	98	8	16	8	10	65	21	140	11	15	20	22,000
725012	250	144	124	36	6	—	178	64	100	8	16	8	10	65	21	140	11	15	20	26,000
725014	250	168	148	36	12	—	202	64	104	8	16	8	10	65	21	140	11	15	20	30,000
725016	250	192	172	38	12	—	226	64	106	8	16	8	10	65	21	140	11	15	20	35,000
725020	250	240	201	38	12	—	274	64	110	8	16	8	10	65	21	140	11	15	20	55,000
725024	250	288	246	36	12	20	322	64	120	8	16	8	10	65	21	140	11	15	30	65,000
73208	320	96	76	36	12	—	130	70	104	10	18	8	10	65	19	112	10	13.5	30	24,000
732010	320	120	100	36	12	—	154	70	104	10	18	8	10	65	19	112	10	13.5	30	29,000
732012	320	144	124	36	12	—	178	70	104	10	18	8	10	65	19	112	10	13.5	30	33,000
732014	320	168	148	38	12	—	202	70	110	10	18	8	10	65	19	112	10	13.5	30	38,000
732016	320	192	172	38	12	—	226	70	114	10	18	8	10	65	19	112	10	13.5	30	44,000
732020	320	240	201	36	12	20	274	70	130	10	18	8	10	65	19	112	10	13.5	30	62,000
732024	320	288	249	36	12	24	322	70	136	10	18	8	10	65	19	112	10	13.5	30	72,000
740010	400	120	100	38	12	—	154	74	114	10	18	8	10	65	18	112	10	13	40	38,000
740012	400	144	124	38	12	—	178	74	114	10	18	8	10	65	18	112	10	13	40	43,000
740014	400	168	148	38	12	—	202	74	121	10	18	8	10	65	18	112	10	13	40	48,000
740016	400	192	172	38	12	—	226	74	121	10	18	8	10	65	18	112	10	13	40	54,000
740020	400	240	201	36	12	22	274	74	134	10	18	8	10	65	18	112	10	13	40	67,000
740024	400	288	248	36	12	42	322	74	140	10	18	8	10	65	18	112	10	13	40	78,000
750012	500	144	122	38	12	—	178	80	118	10	18	8	12	65	18	106	10	12.5	50	54,000
750014	500	168	146	38	12	—	202	80	124	10	18	8	12	65	18	106	10	12.5	50	58,000
750016	500	192	172	36	12	10	226	80	128	10	18	8	12	65	18	106	10	12.5	50	60,000
750020	500	240	201	36	12	48	274	80	140	10	18	8	12	65	18	106	10	12.5	50	82,000
750024	500	288	248	36	12	52	322	80	154	10	18	8	12	65	18	106	10	12.5	50	92,000

DIMENSIONS ARE FOR REFERENCE ONLY AND SUBJECT TO CHANGE.  
MACHINE SHIPPING WIDTHS AND WEIGHTS MAY CHANGE PENDING OPTIONAL ACCESSORIES.

# DIMENSIONS

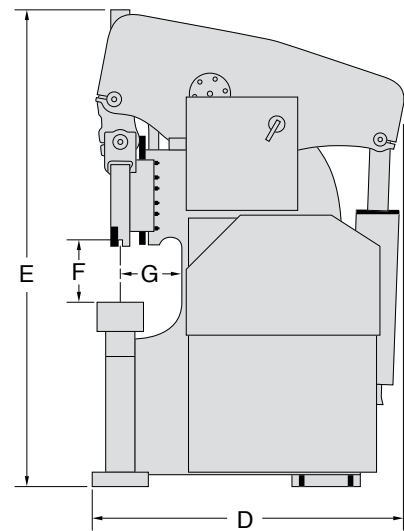
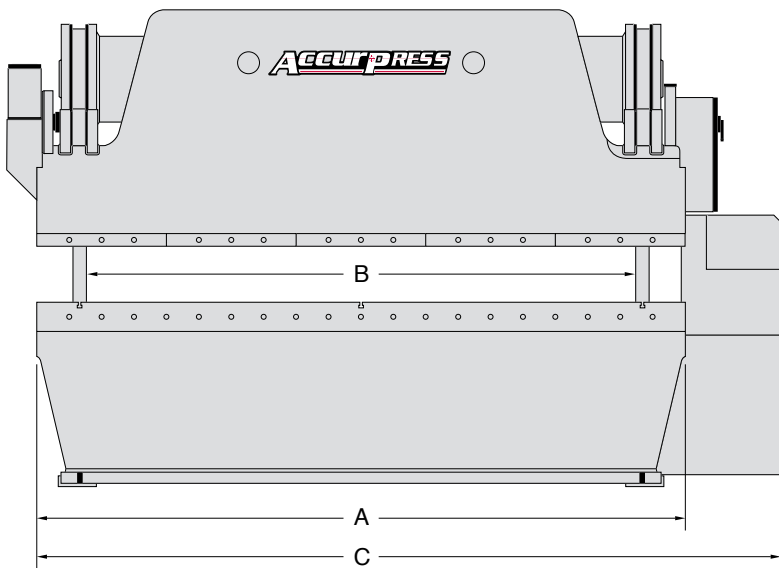

Ram Open Height (F) is measured from the top of the bed to the bottom of the ram.

## DEALER SUPPORT NETWORK

Accurpress Sales & Service is provided by an Authorized Dealer Network.  
All of our Dealers are factory trained and supported to provide you  
with knowledgeable, competent and local service.

